

Sales Code: XTY109S

Barcode: 5056678460238

Brand: nuie

Description: Concealed Cistern Frame With Matt White Square Flush Plate

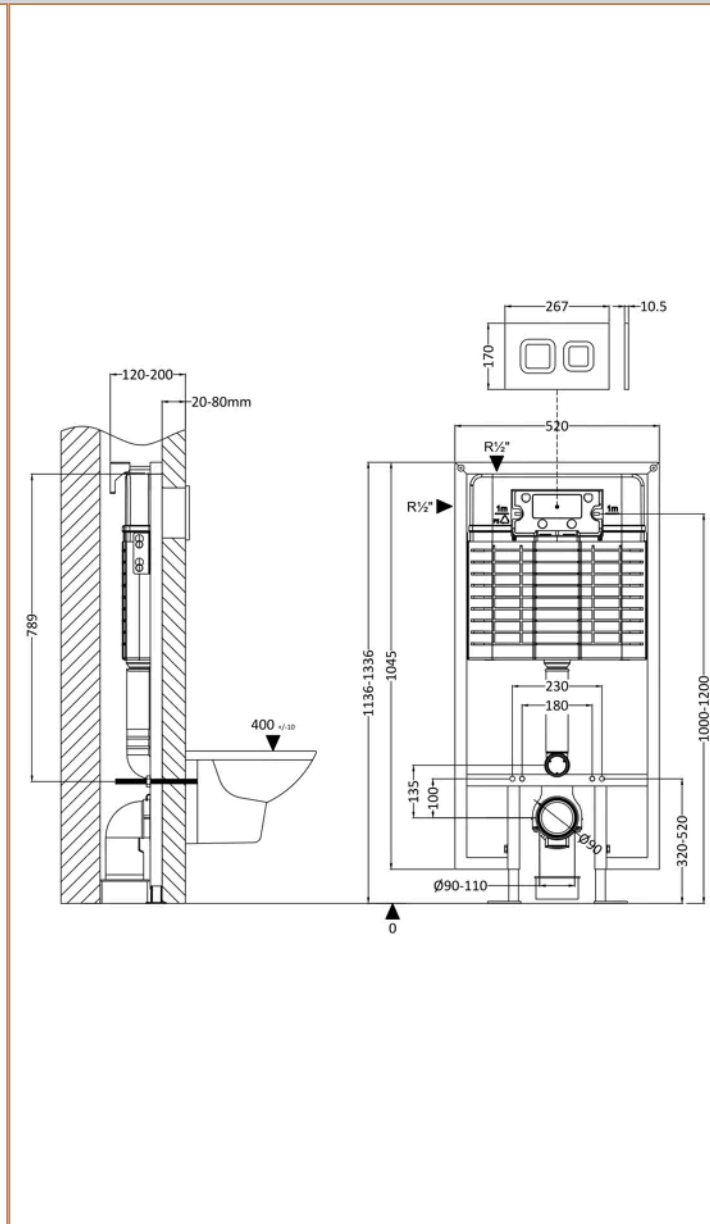

Product Dimensions

Product	1136 x 520 x 204mm (H x W x D)
Packaged	1125 x 560 x 160mm (H x W x D)
Nett Weight	11.5 kg
Packaged Weight	12 kg

Product Details

Country of Origin	China
Product Material	Stainless Steel
Colour/Finish	Matt White
Style	Contemporary