

**Sales Code:** VTM550

**Barcode:** 5055369071050

**Brand:** nuie

**Description:** nuie Mayford 550mm Gloss White 2 Door Floor Standing Cabinet With Square Basin

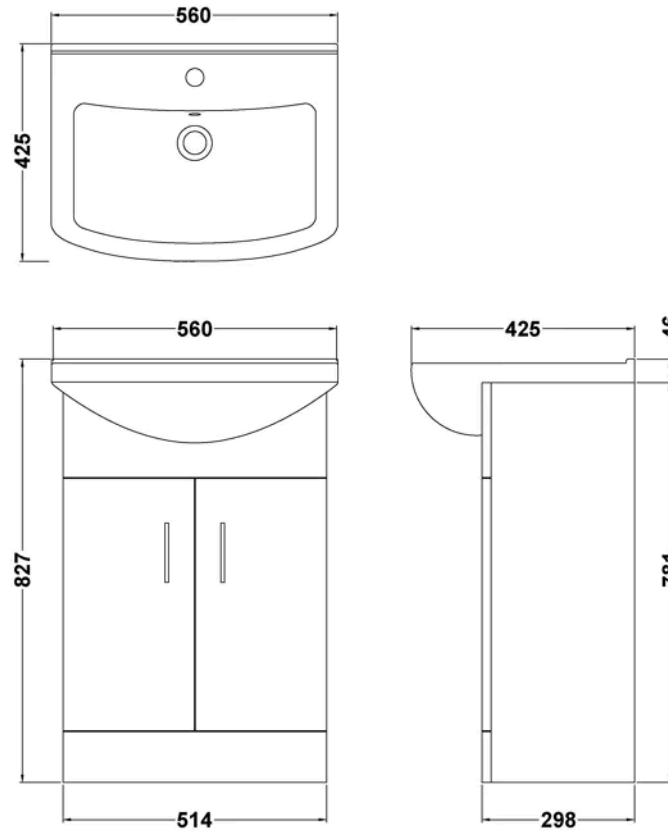

### Product Dimensions

Product	836 x 550 x 425mm (H x W x D)
Packaged	550 x 550 x 550mm (H x W x D)
Nett Weight	0.55 kg
Packaged Weight	0.55 kg

### Product Details

Country of Origin	China
Product Material	Mfc Painted Gloss
Colour/Finish	Gloss White
Mount Type	Floor
Style	Contemporary
Handle Type	D Shape
Construction Method	Cam & Wood Dowel
Construction Type	Rigid
Fsc Certified	Yes
Handles Included	Yes
Inner Bowl Height	110 mm
Leg Set Included	No
Legs Included	No
Material Thickness	16 mm
No. Doors	2
No. Of Tapholes	1
No. Shelves	1
Number Of Bowls	1
Number Of Shelves	1
Overflow Included	Yes
Tap Included	No
Waste Included	No
Waste Shroud	No