

Sales Code: LUN1405

Barcode: 5056462646169

Brand: nuie

Description: nuie Lunar 600mm Soft Black 1 Drawer Wall Hung Vanity Unit With Polymarble Basin

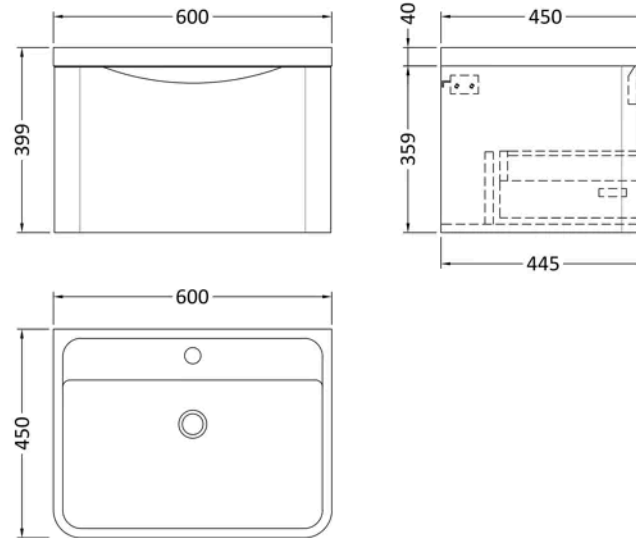

Product Dimensions

Product	399 x 600 x 445mm (H x W x D)
Packaged	550 x 550 x 550mm (H x W x D)
Nett Weight	34.32 kg
Packaged Weight	0 kg

Product Details

Country of Origin	China
Product Material	Mfc Painted Matt, Polymarble
Colour/Finish	Soft Black
Mount Type	Wall Hung
Style	Contemporary
Handle Type	Inset
Construction Method	Cam & Wood Dowel
Construction Type	Rigid
Drawer Type	80mm High Metal S/C Inc Gallery
Fsc Certified	Yes
Handles Included	No
Inner Bowl Depth	315 mm
Inner Bowl Height	110 mm
Inner Bowl Width	550 mm
Leg Set Included	No
Legs Included	No
Material Thickness	18 mm
No. Drawers	1
No. Of Tapholes	1
Number Of Bowls	1
Overflow Cover Included	Yes
Overflow Included	Yes
Tap Included	No
Waste Included	No
Waste Shroud	Yes