

Sales Code:
CT115T1000

Barcode: 5056211883920

Brand: Fireclay
Sinks

Description: nuie 1010mm x 525mm Fireclay White 1.5 Bowl Rectangular Countertop Drainer Sink

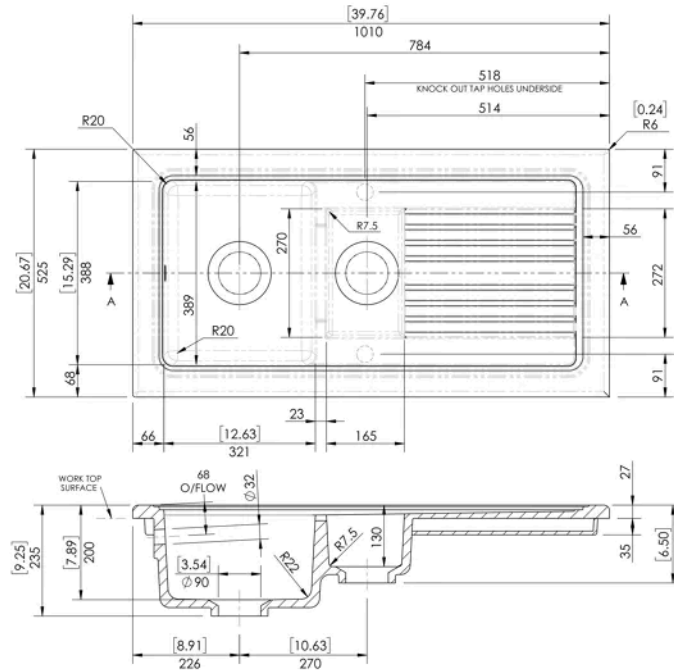

Product Dimensions

Product	235 x 1010 x 525mm (H x W x D)
Packaged	250 x 1030 x 540mm (H x W x D)
Nett Weight	29.5 kg
Packaged Weight	30 kg

Product Details

Country of Origin	United Arab Emirates
Product Material	Fireclay
Colour/Finish	White
Style	Traditional
Inner Bowl Depth	389 mm
Inner Bowl Height	200 mm
Inner Bowl Width	321 mm
No. Of Tapholes	No Tapholes
Number Of Bowls	1.5
Overflow Included	Yes
Sink Thickness	22 mm
Tap Included	No
Waste Included	No
Waste Size Required	90mm